

Project Name: _____

Item #: _____

Quantity: _____

SMALL APPLIANCE VENTLESS HOODS

Equipex MISTRAL-X SA Vent with Fire Suppression Pre-Piping

SKU	MISTRAL-X
APPLICATION	Pre-piping for ANSUL Fire Suppression System
DIMENSIONS	34"H x 31"W x 31"D
MATERIAL	304 Stainless Steel, #4 Finish

DESCRIPTION

The MISTRAL-X SA Vent is a countertop ventilation system for small cooking equipment located outside the range of a kitchen ventilation hood and ready to be hooked up to your external ANSUL fire suppression system by others.

FEATURES:

- UL-710B approved with ANSUL fire suppression system pre-piping (balance of system by others)
- 3-stage internal air filtration removes grease-laden vapors, smoke, and odors to improve air quality
- Fully assembled, easy installation
- Integral appliance receptacle (up to 50 amps)
- Patented design
- Convenience surface light for cooking area
- Base Capacity: Up to 150 lbs., 26"W x 20"D



WARRANTY

One-year parts & labor (excluding filters)

CERTIFICATIONS

- UL710B Certified, Recirculating Systems
- UL CSA 22.2 Certified, Canada Standards
- EPA 202 Grease Extraction Test Method Certified
- UL Classified to NSF/ ANSI 2
- UL Classified to EPH (Environmental & Public Health)
- New York City Fire Code Section 901.4.5.



SPECIFICATIONS

MODEL	DIMENSIONS (HWD)	CAPACITY	ELECTRICAL	PLUG/ CORD	HVAC	SHIP WEIGHT
MISTRAL-X	34" x 31" x 31" (includes 4" legs) Base: 5 x 26" x 20"	Up to 150 lbs, Dimensions up to 26"W x 20"D	Hood: 120V, Single Phase, 5.5 Amp	NEMA 5-15P, 6' Cord*	500 CFM	180 lbs. Must be shipped common carrier.
			Appliance Receptacle (installed): 120V or 208/240V, Single Phase up to 50 Amps	Matching Plug, 6' Cord*		

Clearance: 8" at right and 2" at left sides, 1" at rear - allow 8" for removal of grease cup on right.

*Cord exit located in right rear side of base for hood; appliance receptacle in left rear side with cord & plug.

CONSTRUCTION

- Fire suppression system pre-piping - ready to be hooked up to your external fire suppression system by others
- Configuration complies with UL-710B standard: internal fire damper, plenum protection, surface protection, 2 fusible link holders
 - Chrome-plated Ansul pre-piping fire suppression surface protection: pre-piping with appliance-specific nozzles installed for flow and angle based on appliance
- Internal fire damper with fusible link closes to stop fire from being emitted into room
- Integral appliance receptacle for plug & play with cooking appliances- no expensive electrical field work needed
- Filter safety features: a) must be in place for hood to operate, b) if filters require cleaning/ replacement, hood and connected appliance turn off and alert light illuminates
- Removable sides for cleaning
- 3-stage air filtration with airflow capture through the front and return air on the left side, no need to temper air
- Additional Certifications: IMC 507.2 Type 1 hood exception

AVAILABLE ACCESSORIES

- Additional particulate & carbon filters
- Front platform extension
- 1" adjustable feet

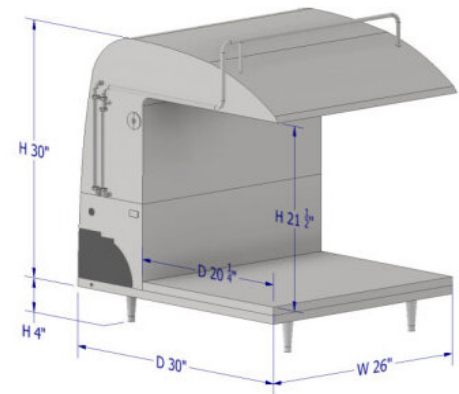

APPLICATIONS

Designed for use with cooking equipment up to 7000W: convection and bake ovens, panini grills, conveyor/ stationary toasters, pizza ovens, crepe makers, waffle bakers, induction ranges, steamers, microwave ovens, combi ovens, cheese melters/ salamanders, electric hot plates, rotisseries.

NOTES/ CONDITIONS

- Fire system must be installed by certified ANSUL fire suppression system technician
- Find CAD/ Revit files on KCL
- Design & functional patents