



CONVEYOR OVEN

C O N V E Y O R O V E N

Perfect way to toast sandwiches, bread and bagels with precision in compact footprint...

- Quartz infrared heat
- Adjustable conveyor speed
- 12" wide conveyor belt
- Pull-out bottom crumb tray
- Full or partial power for perfect toasting
- Free-standing with adjustable feet
- Stainless steel construction
- Pilot lights
- Easy to clean

Conveyor Oven



Conveyor Toaster



VOYAGER

CT540

208/240V



FEATURES:

- Independent top and bottom heat activation
- Front load/unload or front load/rear unload configurations
- 3 1/4" H entry x 12" wide
- Ideal for toasting all types of bread and bagels

ODYSSEY

CT3000

208/240V



FEATURES:

- Reversible/remote control panel
- Upper warming sheet
- Adjustable entry/exit opening from 1 1/4" to 3 1/2" high x 12" wide
- Half or full power setting
- Ideal for toasting and heating all types of sandwiches



100 NIANTIC AVENUE; SUITE 104 PROVIDENCE, RI 02907
TEL: (401)273-3300 FAX: (401)273-3328 E-mail: sales@equipex.com
www.equipex.com





CONVEYOR OVEN AND TOASTER

Perfect way to toast sandwiches, bread and bagels with precision in a compact footprint...

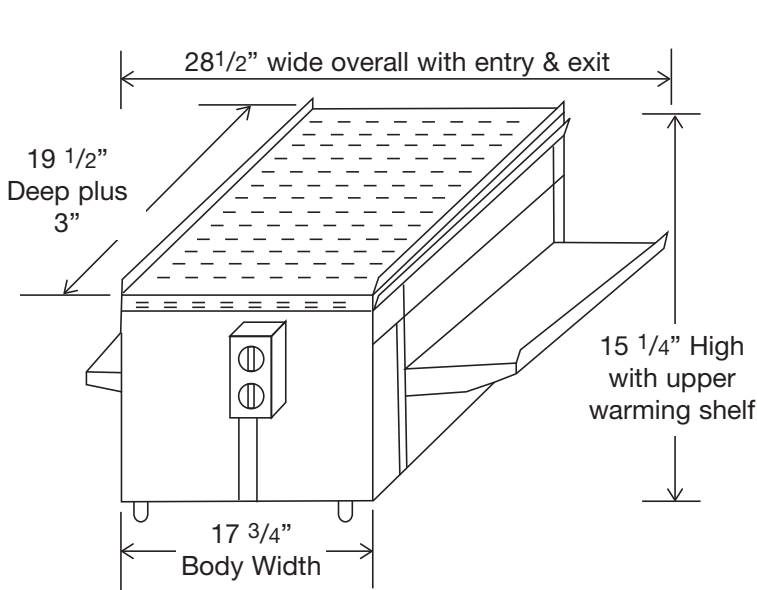

CT3000

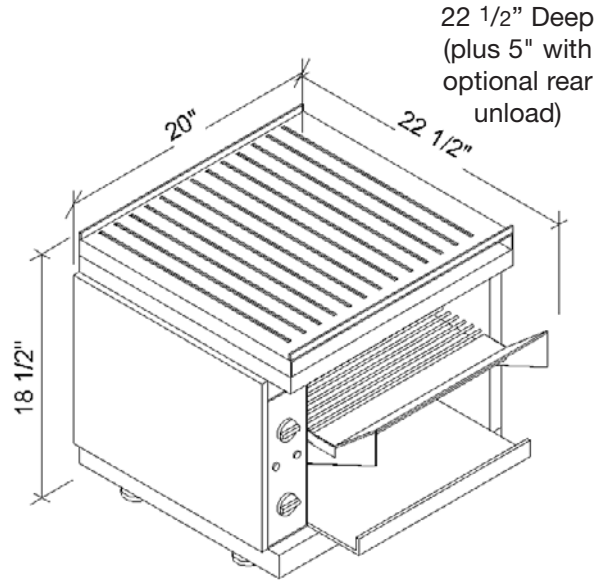

CT540

SPECIFICATIONS

INSTALLATION CLEARANCE: 2" EACH SIDE AND BACK

MODEL	ELECTRICAL	DIMENSIONS W x D x H	WORK SURFACE	SHIPPING WEIGHT	NEMA PLUG
CT3000	208/240V, 1PH 3.4KW, 15/17 Amps	28 1/2"W x 19 1/2"D x 15 1/4"H (note: add 3" to depth for control box)	12" wide conveyor x 1 1/4" to 3 1/2" high	55lbs	6-20P
CT540	208/240V, 1PH 3.0KW, 13/15 Amps	18"W x 21"D x 14"H (note: add 13" to depth for rear unload)	12" wide conveyor x 3 1/4" high	55lbs	6-20P

GRILLING CAPACITY

MODEL	SLICES/HOUR*	AVERAGE TIME
CT3000	540	1 1/2" Minute
CT540	540	1 1/2" Minute

* Estimated per hour; may vary with actual sizes and types of food products

*All equipment must be plugged into a dedicated circuit of the proper ratings.

WARRANTY: Limited one year parts and labor



100 NIAN TIC AVENUE; SUITE 104 PROVIDENCE, RI 02907
 TEL: (401)273-3300 FAX: (401)273-3328 E-mail: sales@equipex.com
 www.equipex.com

